

NOTE: DO NOT DISCARD the Parts List from the Instruction Bulletin. Place the Parts List in the appropriate place in the machine manual for future reference. Retaining the Parts List will make it easier to reorder individual parts and will save the cost of ordering an entire kit.

NOTE: Numbers in parenthesis () are reference numbers for parts listed in Bill of Materials.

Installation instructions for **kit number 9003442**

SYNOPSIS:

This kit contains the parts needed to install the front cover seal kit onto M20/T20 machines. Please follow step-by-step instructions.

SPECIAL TOOLS / CONSIDERATIONS: NONE

(Estimated time to complete: 1 hour)

PREPARATION:

1. Park the machine on a clean level surface, turn off the machine, remove the key, and set the parking brake.

FOR SAFETY: Before leaving or servicing machine, stop on level surface, turn off machine, and remove key.

INSTALLATION:

1. Open the front shroud.
2. Remove the old seal, staples, and plastic retainer from the front shroud. Discard the old seal and plastic retainer.
3. Clean all dirt and debris from the area of the front shroud cover where the new seal (4) will be mounted. Refer to Fig. 2.
4. Peel the backing from the seal (4) and install the seal onto the front shroud. Orient the seal so the opening in the seal points to the inside of the front shroud. Refer to Fig. 1 and Fig. 2.
5. Pull the top portion of the seal (4) out of the way and hold the seal mounting plate (1) up to the seal. Use the seal mounting plate as a template and drill a 7/64" hole through each hole in the seal mounting plate, through the seal, and through the front shroud. Refer to Fig. 1 and Fig. 2.

6. Use six screws (3) to install the seal mounting plate (1) onto the front shroud. Torque the screws to 15 in. lbs (1.7 Nm). Refer to Fig. 2.
7. Pull the top portion of the seal (4) out of the way and hold the straight seal mounting plate (2) up to the seal. Use the seal mounting plate as a template and drill a 7/64" hole through each hole in the seal mounting plate, through the seal, and through the front shroud. Refer to Fig. 1 and Fig. 2.
8. Use four screws (3) to install the straight seal mounting plate (2) onto the front shroud. Torque the screws to 15 in. lbs (1.7 Nm). Refer to Fig. 2.



FIG. 1

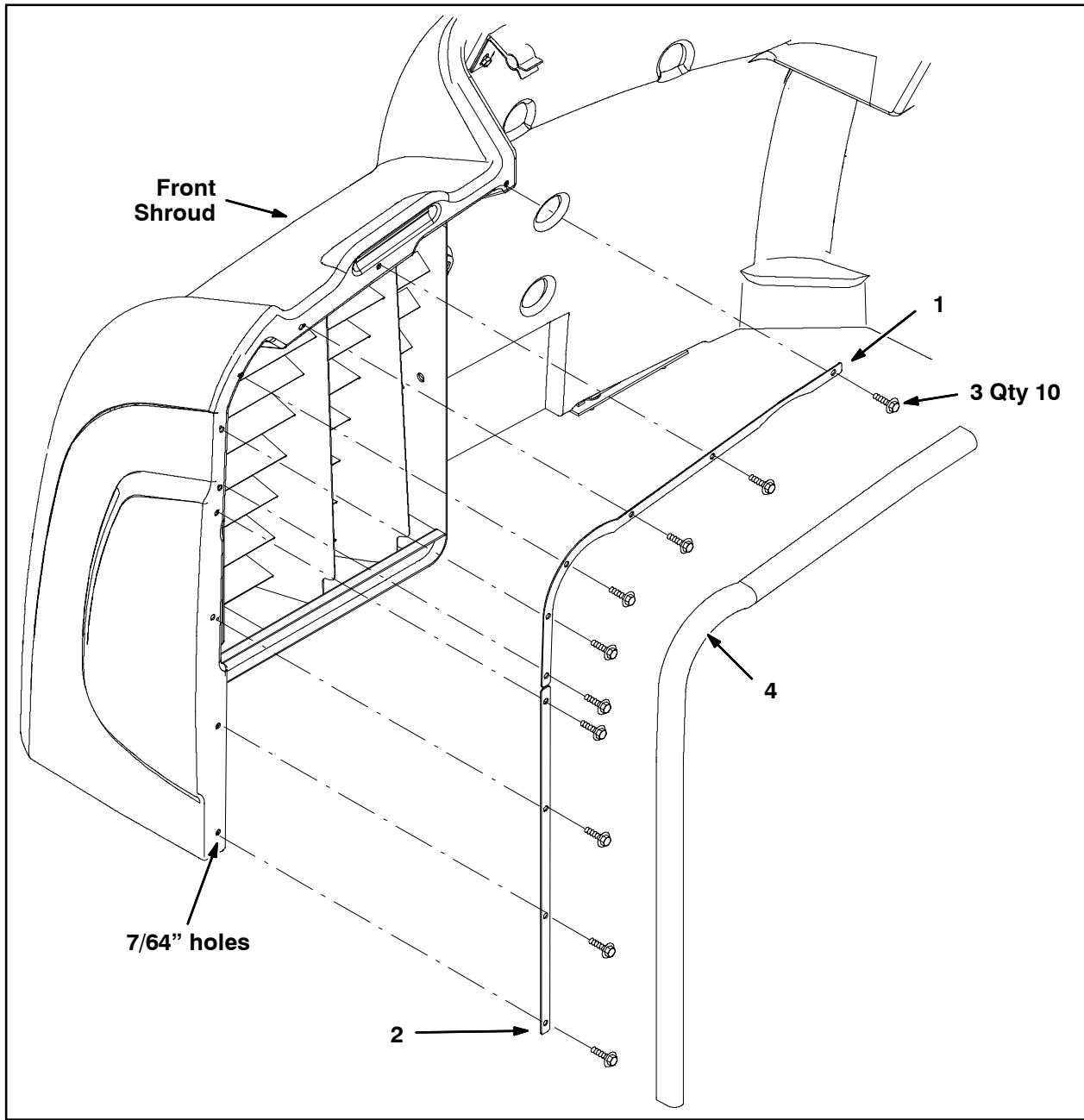

FIG. 2

Bill of Materials for Seal Kit, Cover, Front-9003442

Ref.	Tennant Part No.	Description	Qty.
▽	9003442	Seal Kit, Cover, Front	1
▲	1 1029652	Plate, Mtg, Seal	1
▲	2 1029545	Plate, Mtg, Seal	1
▲	3 360943	Screw, Pan, #10-14 X 0.75, F/Plstc	10
▲	4 1031543	Seal, Aftmkt, Sponge, 0.88 1.00W 08ft	1

TENNANT COMPANY
P. O. Box 1452
Minneapolis, MN 55440-1452